



Video Solution on Website:-

<https://physicsaholics.com/home/courseDetails/76>

Video Solution on YouTube:-

<https://youtu.be/INfECcGDkjc>

Written Solution on Website:-

<https://physicsaholics.com/note/notesDetails/81>

- Q 1. Centre of mass is a point
- Which is geometric center of a body
  - From which distance of particles are same
  - Which moves exactly as motion described by newton's second law.
  - Which represents average position of all masses of system.

- Q 2. Two semicircular rings of linear mass densities  $\lambda$  and  $2\lambda$  and of radius 'R' each are joined to form a complete ring. The distance of the center of the mass of complete ring from its geometrical centre is :
- $\frac{3R}{8\pi}$
  - $\frac{2R}{3\pi}$
  - $\frac{3R}{4\pi}$
  - none of these

- Q 3. A uniform thin rod is bent in the form of closed loop ABCDEFA as shown in the figure. The x-coordinate of the centre of mass of the system is

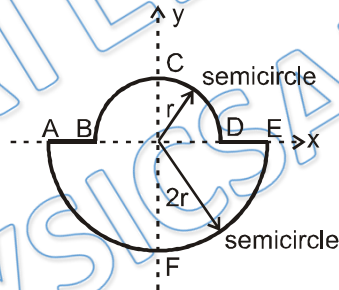

- $\frac{2r}{\pi}$
  - $-\frac{6r}{3\pi+2}$
  - $-\frac{2r}{\pi}$
  - Zero
- Q 4. Three identical metal balls each of radius  $r$  are placed touching each other on a horizontal surface such that an equilateral triangle is formed, when centres of three balls are joined. The centre of the mass of system is located in:
- horizontal surface
  - centre of one of the balls
  - line joining centres of any two balls
  - point of intersection of the medians of equilateral triangle
- Q 5. Assuming potential energy 'U' at ground level to be zero. All objects are made up of same material.  $U_P$  = Potential energy of solid sphere  $U_Q$  = Potential energy of solid cube  $U_R$  = Potential energy of solid cone  $U_S$  = Potential energy of solid cylinder

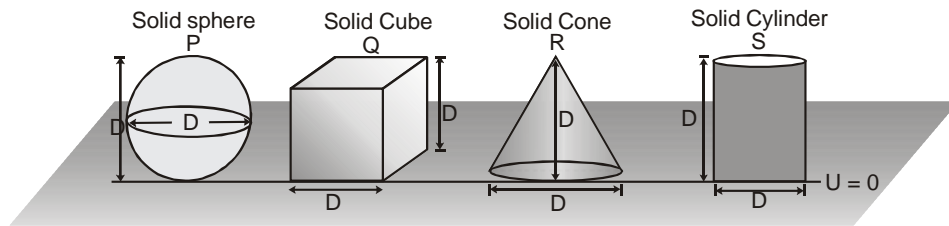

- (a)  $U_S > U_P$       (b)  $U_Q > U_S$       (c)  $U_P > U_Q$       (d)  $U_P > U_S$

- Q 6. Seven particles, each of mass  $m$  are placed at the seven corners of a cube of side ' $a$ ', but one corner is vacant, as shown in figure. The co-ordinates of the centre of mass of the system is :

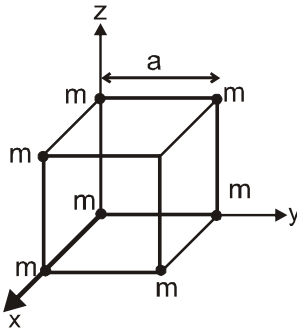

- (a)  $\left(\frac{2a}{7}, \frac{2a}{7}, \frac{2a}{7}\right)$       (b)  $\left(\frac{3a}{7}, \frac{3a}{7}, \frac{3a}{7}\right)$   
 (c)  $\left(\frac{a}{3}, \frac{a}{3}, \frac{a}{3}\right)$       (d)  $\left(\frac{5a}{11}, \frac{5a}{11}, \frac{5a}{11}\right)$

- Q 7. Two semicircular discs made of same material having radius  $r$  and  $2r$  are placed as shown in figure. Find out the center of mass of structure.

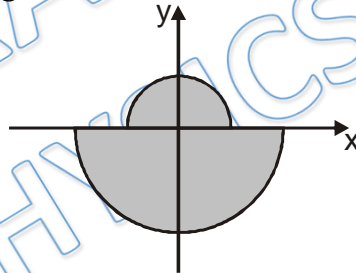

- (a)  $\left(0, \frac{-28r}{5\pi}\right)$       (b)  $\left(0, \frac{-28r}{15\pi}\right)$   
 (c)  $\left(0, \frac{-9r}{5\pi}\right)$       (d)  $\left(0, \frac{-9r}{15\pi}\right)$

- Q 8. In each situation of column-I a mass distribution is given and information regarding  $x$  and  $y$ -coordinate of centre of mass is given in column-II. Match the figures in column-I with corresponding information of centre of mass in column-II.

Column-I		Column-II	
(A)	An equilateral triangular wire frame is made using three thin uniform rods of mass per unit lengths $\lambda$ , $2\lambda$ and $3\lambda$ as shown		(p) $x_{cm} \geq 0$
(B)	A square frame is made using four thin uniform rods of mass per unit length lengths $\lambda$ , $2\lambda$ , $3\lambda$ and $4\lambda$ as shown		(q) $y_{cm} \geq 0$
(C)	A circular wire frame is made of two uniform semicircular wires of same radius and of mass per unit length $\lambda$ and $2\lambda$ as shown		(r) $x_{cm} < 0$
(D)	A circular wire frame is made of four uniform quarter circular wires of same radius and mass per unit length $\lambda$ , $2\lambda$ , $3\lambda$ and $4\lambda$ as shown		(s) $y_{cm} < 0$

- Q 9. In the figure shown find out the distance of centre of mass of a system of a uniform circular plate of radius  $3R$  from  $O$  in which a hole of radius  $R$  is cut whose centre is at  $2R$  distance from centre of large circular plate.

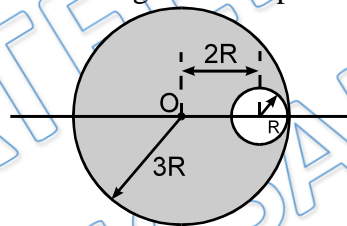

- (a)  $R/4$                       (b)  $R/5$                       (c)  $R/2$                       (d) none of these

- Q 10. From the uniform disc of radius  $4R$  two small disc of radius  $R$  are cut off. The centre of mass of the new structure will be : (Centre of lower circular cavity lies on x-axis and centre of upper circular cavity lies on y-axis )

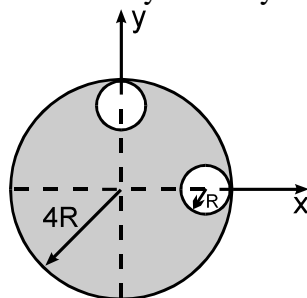

- (a)  $\hat{i}\frac{R}{5} + \hat{j}\frac{R}{5}$                       (b)  $-\hat{i}\frac{R}{5} + \hat{j}\frac{R}{5}$   
 (c)  $-\hat{i}\frac{R}{5} - \hat{j}\frac{R}{5}$                       (d)  $-\frac{3R}{14}(\hat{i} + \hat{j})$

Q 11. From a uniform square plate the shaded portions are removed as shown in figure. The coordinates of centre of mass of the remaining plate are  $x, y$ . Axes and origin are shown in figure.

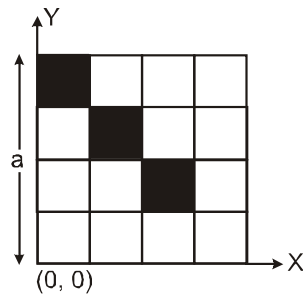

- (a)  $x < \frac{a}{2}, y < \frac{a}{2}$                       (b)  $x > \frac{a}{2}, y < \frac{a}{2}$   
 (c)  $x < \frac{a}{2}, y > \frac{a}{2}$                       (d)  $x > \frac{a}{2}, y > \frac{a}{2}$

Q 12. A homogenous body consists of right circular conical portion attached to a hemispherical portion of radius  $R = \sqrt{3}$  m. Determine the height  $H$  of cone if the centre of gravity of the composite body coincides with the center  $O$  of the circular base of the cone.

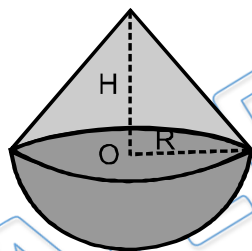

- (a) 1m    (b) 2m  
 (c) 3m    (d) 4m

Q 13. Match the following

Following is a solid object formed by three parts which are a solid hemisphere, solid cylinder and a solid cone. The material of the object is uniform and all the above parts are made up of the same material. The dimensions of the objects are indicated in the figure. The points A, B, C, D, E lie on the common axis of the system as shown in the figure. Point C is the centre of the cylinder.

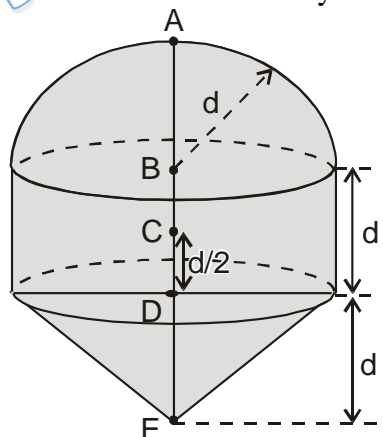



### Column I

- (A) Centre of mass of the whole system lies on segment
- (B) Centre of mass of the system of only hemisphere and cylinder lies on segment
- (C) Centre of mass of the system of only cone and cylinder lies on segment
- (D) Centre of mass of the system of only hemisphere and cone lies on segment

### Column II

- (p) AB
- (q) BC
- (r) CD
- (s) DE

- Q 14. An object comprises of a uniform ring of radius  $R$  and its uniform chord  $AB$  (not necessarily made of the same material) as shown. Which of the following cannot be the centre of mass of the object?

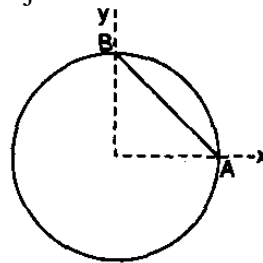

- (a)  $(R/3, R/3)$
- (b)  $(R/\sqrt{2}, R/\sqrt{2})$
- (c)  $(R/4, R/4)$
- (d) None of the above

- Q 15. Section  $AOB$  is cut from a uniform circular plate of radius  $R$ . find distance of centre of mass of  $AOB$  from  $O$  if  $\theta$  is very small angle?

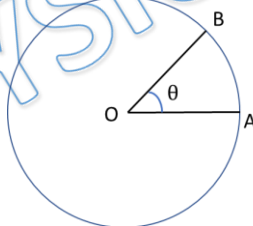

- (a)  $R$
- (b)  $R/2$
- (c)  $2R/3$
- (d)  $R/3$

- Q 16. A uniform solid sphere of radius  $R$  is divided into four equal parts. Distance of centre of mass of one part from centre of complete sphere is

- (a)  $3R/8$
- (b)  $3\sqrt{2} R/8$
- (c)  $3R/4$
- (d)  $R/4$

- Q 17. Mark correct statements

- (a) If all particles of a system are lying in a plane centre of mass of system must be in same plane.



- (b) If all particles of a system are lying in a spherical volume centre of mass of system must be in that spherical volume.
- (c) If all particles of a system are lying in a cubical volume centre of mass of system must be in that cubical volume.
- (d) There must be some mass at position of centre of mass

PRATEEK JAIN  
PHYSICSAHOLICS

## Answer Key

<b>Q.1 c, d</b>	<b>Q.2 b</b>	<b>Q.3 d</b>	<b>Q.4 d</b>	<b>Q.5 a, b</b>
<b>Q.6 b</b>	<b>Q.7 b</b>	<b>Q.8 (A) q,r (B) p,s (C) p,s (D) p,s</b>	<b>Q.9 a</b>	<b>Q.10 d</b>
<b>Q.11 b,</b>	<b>Q.12 c</b>	<b>Q.13 (A) q (B) q (C) r (D) q</b>	<b>Q.14 b</b>	<b>Q.15 c</b>
<b>Q.16 b</b>	<b>Q.17 a, b, c</b>			

PLUS **ICONIC\*\***

- ✓ India's Best Educators
- ✓ Interactive Live Classes
- ✓ Structured Courses & PDFs
- ✓ Live Tests & Quizzes
- ✗ Personal Coach
- ✗ Study Planner

24 months	₹2,333/mo	>
No cost EMI	₹56,000	
18 months	₹2,625/mo	>
No cost EMI	₹47,250	
12 months	₹3,208/mo	>
No cost EMI	₹38,500	
6 months	₹4,667/mo	>
No cost EMI	₹28,000	

To be paid as a one-time payment

[View all plans](#)

 Add a referral code APPLY

# PHYSICSLIVE

PLUS **ICONIC\*\***

- ✓ India's Best Educators
- ✓ Interactive Live Classes
- ✓ Structured Courses & PDFs
- ✓ Live Tests & Quizzes
- ✗ Personal Coach
- ✗ Study Planner

24 months	₹2,100/mo	>
No cost EMI	+10% OFF ₹50,400	
18 months	₹2,363/mo	>
No cost EMI	+10% OFF ₹42,525	
12 months	₹2,888/mo	>
No cost EMI	+10% OFF ₹34,650	
6 months	₹4,200/mo	>
No cost EMI	+10% OFF ₹25,200	

To be paid as a one-time payment

[View all plans](#)

 Awesome! **PHYSICSLIVE** code applied ✗

Use code **PHYSICSLIVE** to get 10% OFF on Unacademy PLUS.

# Written Solution

DPP 1 & 2 – C.O.M. of system of particles,  
C.O.M. of continuous mass system

By Physicsaholics Team



Q)1 Centre of mass is a point

$$\vec{F}_{\text{net}} = m \vec{a}_{\text{cm}}$$

$$\vec{r}_{\text{cm}} = \frac{m_1 \vec{r}_1 + m_2 \vec{r}_2 + \dots}{m_1 + m_2 + \dots}$$

av position of all masses

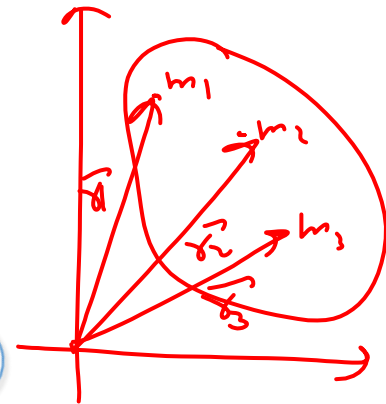

- (a) Which is geometric centre of a body (assume  $n$ , no of particles of unit mass each  $\equiv m$ )
- (b) From which distance of particles are same
- (c) Which moves exactly as motion described by newton's second law.
- (d) Which represents average position of all masses of system.

Q)2 Two semicircular rings of linear mass densities  $\lambda$  and  $2\lambda$  and of radius 'R' each are joined to form a complete ring. The distance of the center of the mass of complete ring from its geometrical centre is :

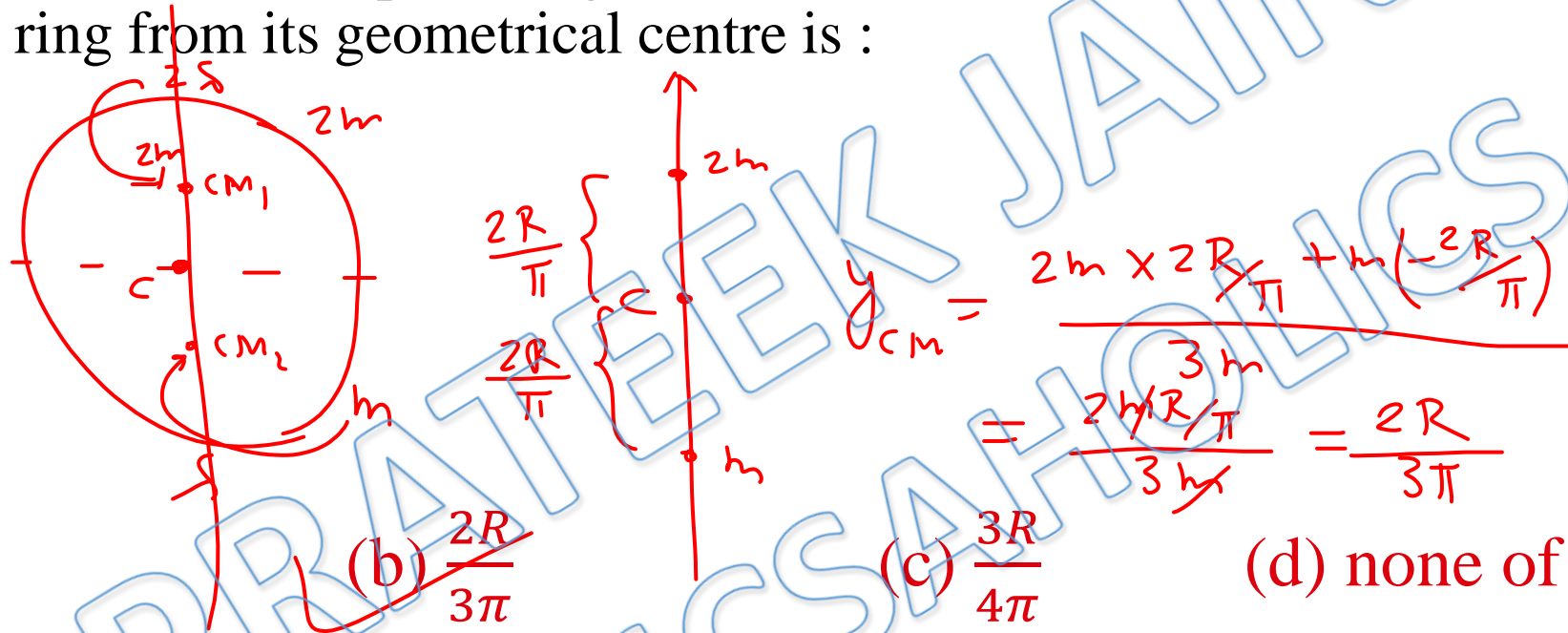

(a)  $\frac{3R}{8\pi}$

(b)  $\frac{2R}{3\pi}$

(c)  $\frac{3R}{4\pi}$

(d) none of these

Q)3 A uniform thin rod is bent in the form of closed loop ABCDEFA as shown in the figure. The x-coordinate of the centre of mass of the system is

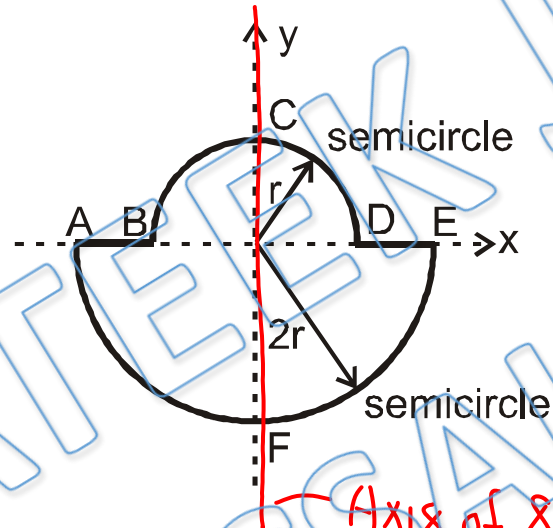

(a)  $\frac{2r}{\pi}$

(b)  $-\frac{6r}{3\pi+2}$

(c)  $-\frac{2r}{\pi}$

(d) Zero

Axis of Symmetry & CM is on this line.

Q) 4 Three identical metal balls each of radius  $r$  are placed touching each other on a horizontal surface such that an equilateral triangle is formed, when centres of three balls are joined. The centre of the mass of system is located in :

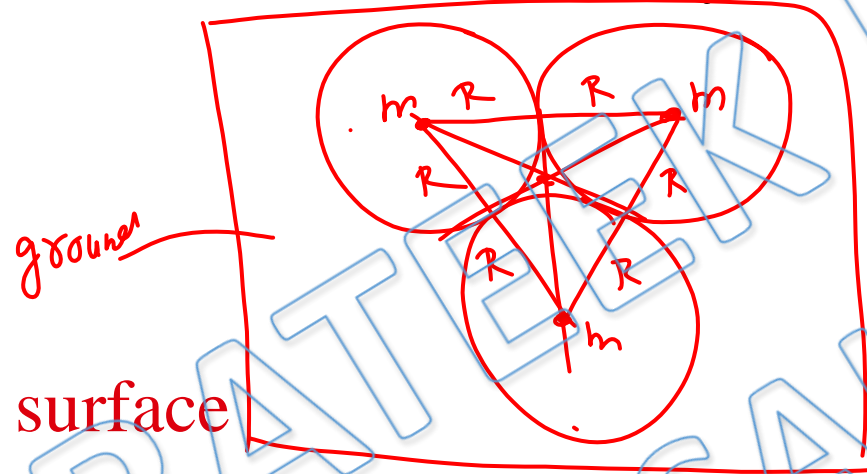

- (a) horizontal surface
- (b) centre of one of the balls
- (c) line joining centres of any two balls
- (d) point of intersection of the medians of equilateral triangle

Q)5 Assuming potential energy 'U' at ground level to be zero. All objects are made up of same material.  $U_P$  = Potential energy of solid sphere  $U_Q$  = Potential energy of solid cube  $U_R$  = Potential energy of solid cone  $U_S$  = Potential energy of solid cylinder

$$m_P = \frac{4}{3} \pi r^3 \rho = \frac{4}{3} \pi \left(\frac{D}{2}\right)^3 \rho$$

$$m_S = \rho \frac{\pi D^2}{4} D = \frac{\rho \pi D^3}{4}$$

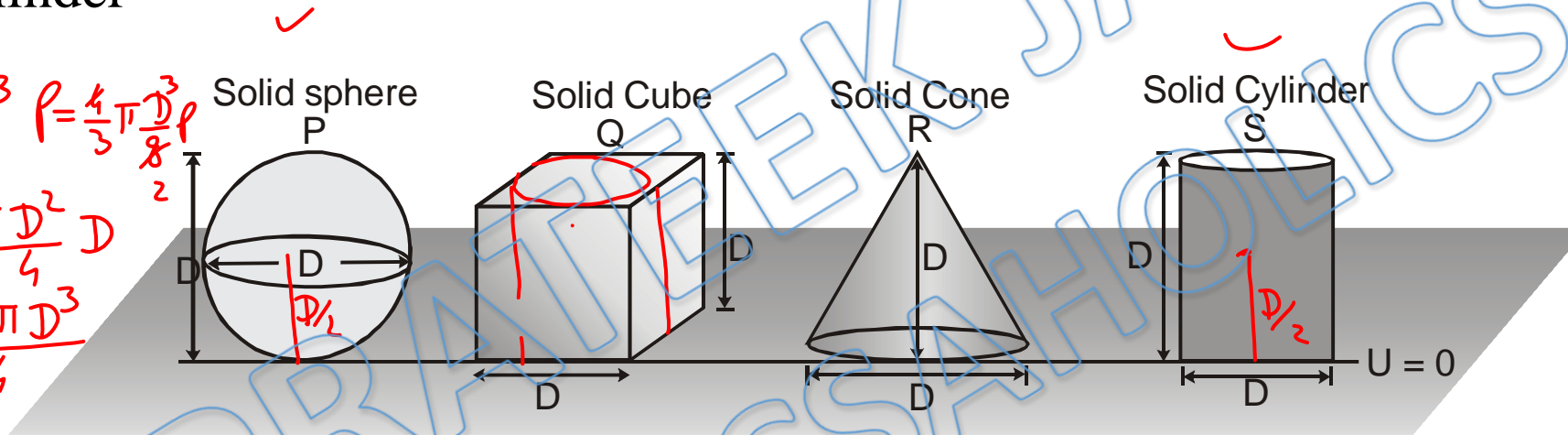

~~(a)  $U_S > U_P$~~

~~(b)  $U_Q > U_S$~~

(c)  $U_P > U_Q$

(d)  $U_P > U_S$

$$m_S > m_P$$

$$\Rightarrow U_S > U_P$$

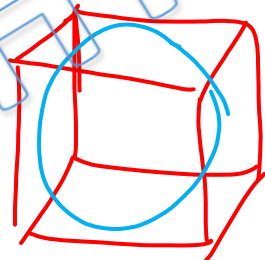

Q)6 Seven particles, each of mass  $m$  are placed at the seven corners of a cube of side ' $a$ ', but one corner is vacant, as shown in figure. The co-ordinates of the centre of mass of the system is :

$$x_{cm} = \frac{4m \times 0 + 3m \times a}{7m} = \frac{3a}{7}$$

- (a)  $\left(\frac{2a}{7}, \frac{2a}{7}, \frac{2a}{7}\right)$   
 (b)  $\left(\frac{3a}{7}, \frac{3a}{7}, \frac{3a}{7}\right)$   
 (c)  $\left(\frac{a}{3}, \frac{a}{3}, \frac{a}{3}\right)$   
 (d)  $\left(\frac{5a}{11}, \frac{5a}{11}, \frac{5a}{11}\right)$

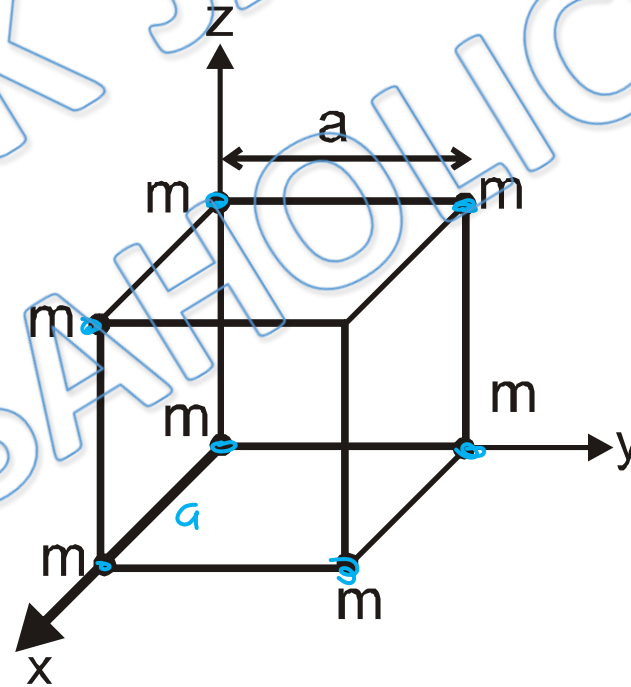

and same thickness

Q) 7 Two semicircular discs made of same material having radius  $r$  and  $2r$  are placed as shown in figure. Find out the center of mass of structure.

$$y_{cm} = \frac{4m \left(-\frac{8r}{3\pi}\right) + m \left(\frac{4r}{3\pi}\right)}{5m}$$
$$= \frac{-28mr/3\pi}{5m}$$
$$= -\frac{28r}{15\pi}$$

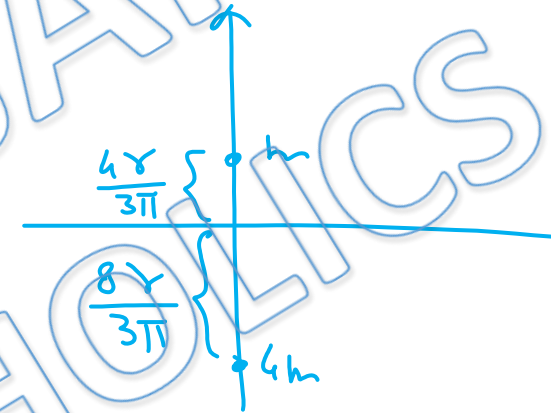
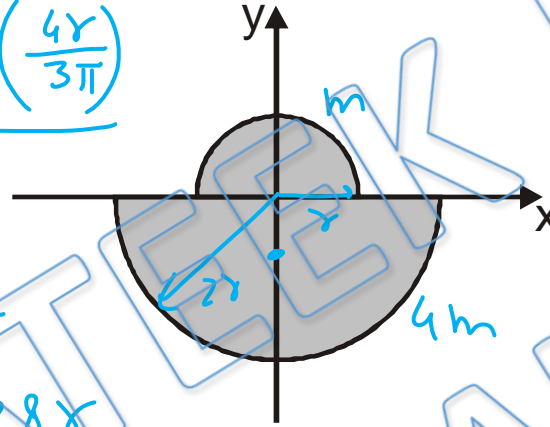

(a)  $\left(0, \frac{-28r}{5\pi}\right)$

(b)  $\left(0, \frac{-28r}{15\pi}\right)$

(c)  $\left(0, \frac{-9r}{5\pi}\right)$

(d)  $\left(0, \frac{-9r}{15\pi}\right)$

Q)8 In each situation of column-I a mass distribution is given and information regarding x and y-coordinate of centre of mass is given in column-II. Match the figures in column-I with corresponding information of centre of mass in column-II.

Column-I		Column-II
(A)	<p>An equilateral triangular wire frame is made using three thin uniform rods of mass per unit lengths <math>\lambda</math>, <math>2\lambda</math> and <math>3\lambda</math> as shown</p> <p><i>(V, Y)</i></p>	<p>(p) <math>x_{cm} \geq 0</math></p>
(B)	<p>A square frame is made using four thin uniform rods of mass per unit length lengths <math>\lambda</math>, <math>2\lambda</math>, <math>3\lambda</math> and <math>4\lambda</math> as shown</p> <p><i>(P, S)</i></p>	<p>(q) <math>x_{cm} = \frac{5m d_1 - 5m d_1}{10L} = 0</math></p> <p><math>y_{cm} \geq 0</math></p>
(C)	<p>A circular wire frame is made of two uniform semicircular wires of same radius and of mass per unit length <math>\lambda</math> and <math>2\lambda</math> as shown</p> <p><i>(P, S)</i></p>	<p>(r) <math>x_{cm} &lt; 0</math></p>
(D)	<p>A circular wire frame is made of four uniform quarter circular wires of same radius and mass per unit length <math>\lambda</math>, <math>2\lambda</math>, <math>3\lambda</math> and <math>4\lambda</math> as shown</p> <p><i>(P, S)</i></p>	<p>(s) <math>y_{cm} &lt; 0</math></p> <p><i>Similar to B</i></p>



Q)9 In the figure shown find out the distance of centre of mass of a system of a uniform circular plate of radius  $3R$  from  $O$  in which a hole of radius  $R$  is cut whose centre is at  $2R$  distance from centre of large circular plate.

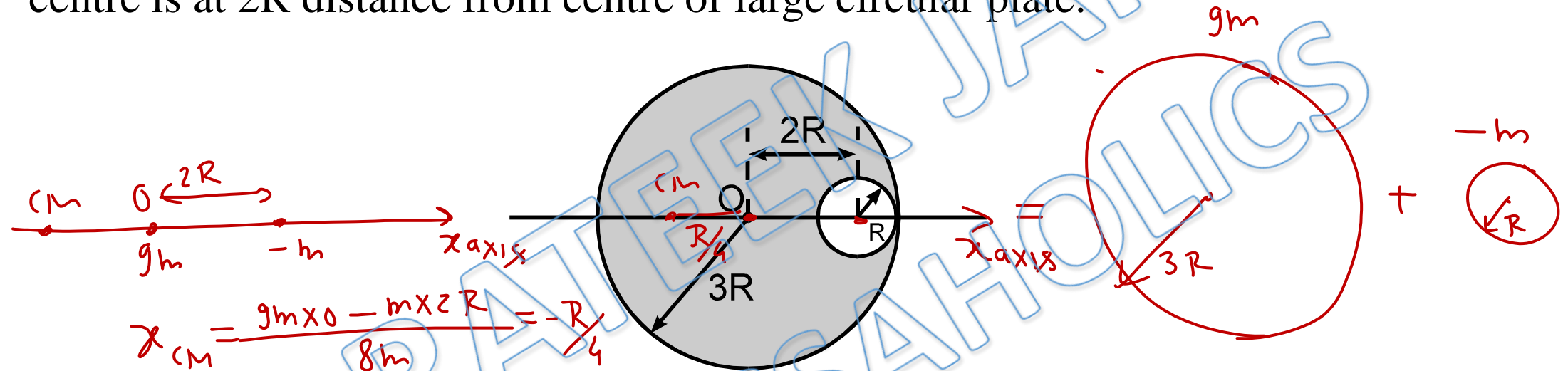

(a)  ~~$R/4$~~

(b)  $R/5$

(c)  $R/2$

(d) none of these

Q)10 From the uniform disc of radius  $4R$  two small disc of radius  $R$  are cut off. The centre of mass of the new structure will be : (Centre of lower circular cavity lies on x-axis and centre of upper circular cavity lies on y-axis )

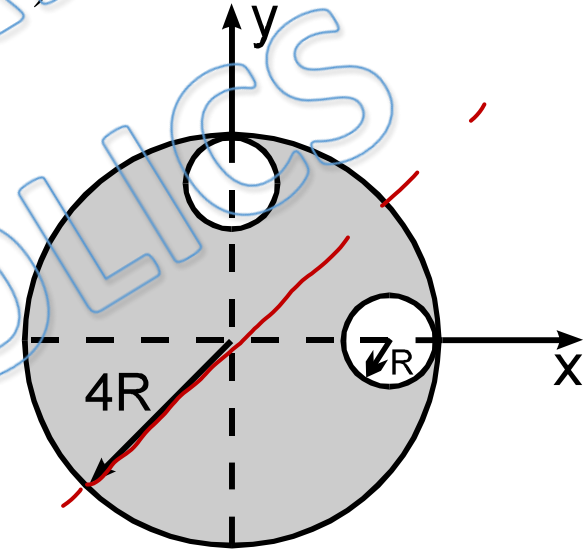
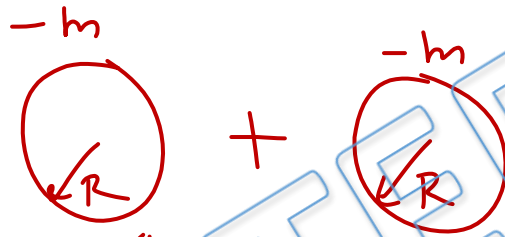

(a)  $\hat{i} \frac{R}{5} + \hat{j} \frac{R}{5}$

(b)  $-\hat{i} \frac{R}{5} + \hat{j} \frac{R}{5}$

(c)  $-\hat{i} \frac{R}{5} - \hat{j} \frac{R}{5}$

(d)  $-\frac{3R}{14} (\hat{i} + \hat{j})$

$$x_{cm} = \frac{16m \times 0 + (-m \times 0) - m \times 3R}{14m} = -\frac{3R}{14}$$

Q)11 From a uniform square plate the shaded portions are removed as shown in figure. The coordinates of centre of mass of the remaining plate are  $x, y$ . Axes and origin are shown in figure.

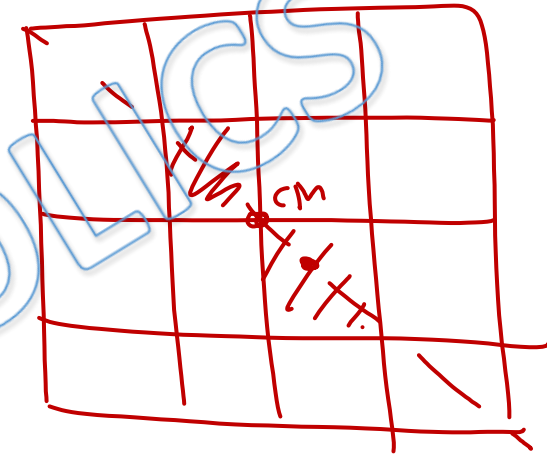
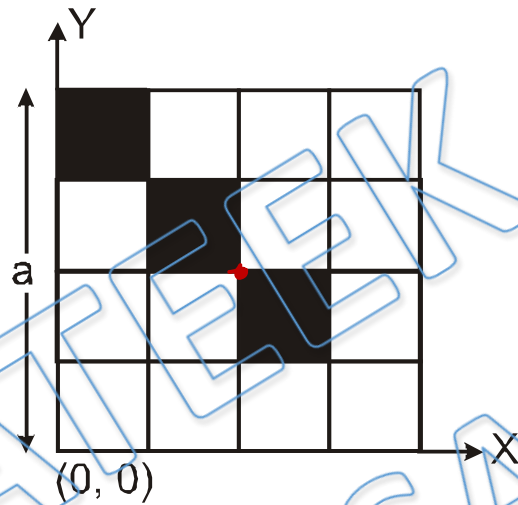

(a)  $x < \frac{a}{2}, y < \frac{a}{2}$   
 (c)  $x < \frac{a}{2}, y > \frac{a}{2}$

(b)  $x > \frac{a}{2}, y < \frac{a}{2}$   
 (d)  $x > \frac{a}{2}, y > \frac{a}{2}$

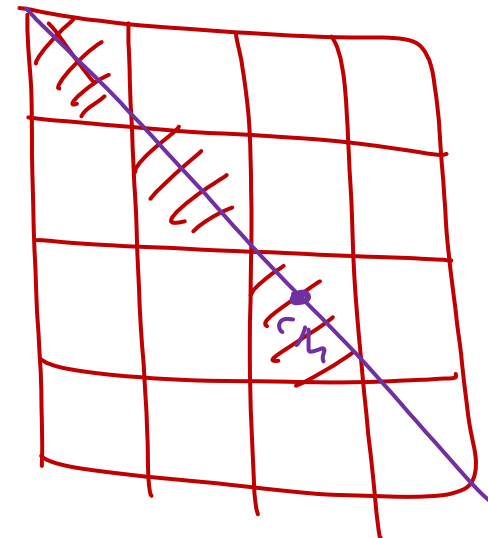

Q)12 A homogenous body consists of right circular conical portion attached to a hemispherical portion of radius  $R = \sqrt{3}$  m. Determine the height  $H$  of cone if the centre of gravity of the composite body coincides with the center  $O$  of the circular base of the cone.

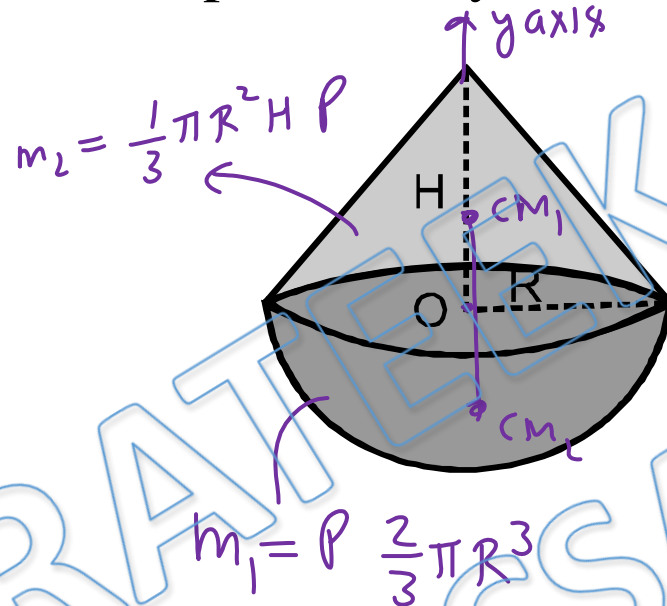

$$y_{CGM} = \frac{m_2 \times H/4 - m_1 \times 3R/8}{m_1 + m_2} = 0$$

$$m_2 \times H/4 = \frac{3}{8} m_1 R$$

$$\frac{\pi R^2 H \rho H}{3 \times 4} = \frac{3}{8} \frac{2}{3} \pi R^3 \rho R$$

$$H^2 = 3R^2$$

$$H = \sqrt{3} R$$

$$= 3$$

- (a) 1m
- (c) 3m

- (b) 2m
- (d) 4m

PRATIKA PHYSICS ONLINE

# Match the following

Q)13 Following is a solid object formed by three parts which are a solid hemisphere, solid cylinder and a solid cone. The material of the object is uniform and all the above parts are made up of the same material. The dimensions of the objects are indicated in the figure. The points A,B,C,D,E lie on the common axis of the system as shown in the figure. Point C is the centre of the cylinder.



$$m_{cy} = \rho \pi d^2 d = m$$

$$m_{sp} = \frac{2}{3} \pi d^3 \rho = \frac{2m}{3}$$

$$m_{conu} = \frac{1}{3} \pi d^2 d \rho = \frac{m}{3}$$

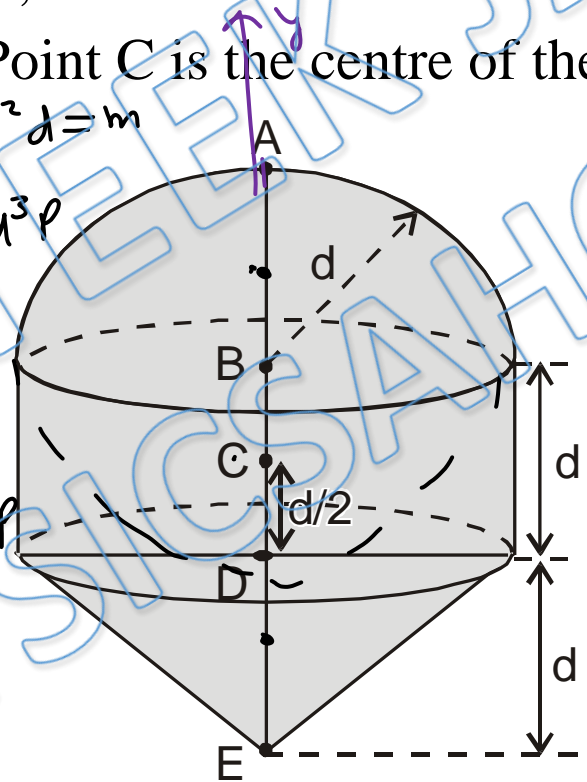

$$y_{cm} = \frac{m \times 0 + \frac{2m}{3} \times \left(\frac{3d}{8} + \frac{d}{2}\right) - \frac{m}{3} \times \frac{3d}{4}}{2m}$$

$$= \frac{\frac{2m}{3} \times \frac{3d+d}{8} - \frac{md}{4}}{2m}$$

$$= \frac{\frac{7d}{12} - \frac{d}{4}}{2}$$

$$= \frac{7d - 3d}{2 \times 12}$$

$$= \frac{4d}{2 \times 12} = \frac{d}{6}$$

## Column I

- (A) Centre of mass of the whole system lies on segment
- (B) Centre of mass of the system of only hemisphere and cylinder lies on segment
- (C) Centre of mass of the system of only cone and cylinder lies on segment
- (D) Centre of mass of the system of only hemisphere and cone lies on segment

## Column II

- (p) AB
- (q) BC
- (r) CD
- (s) DE

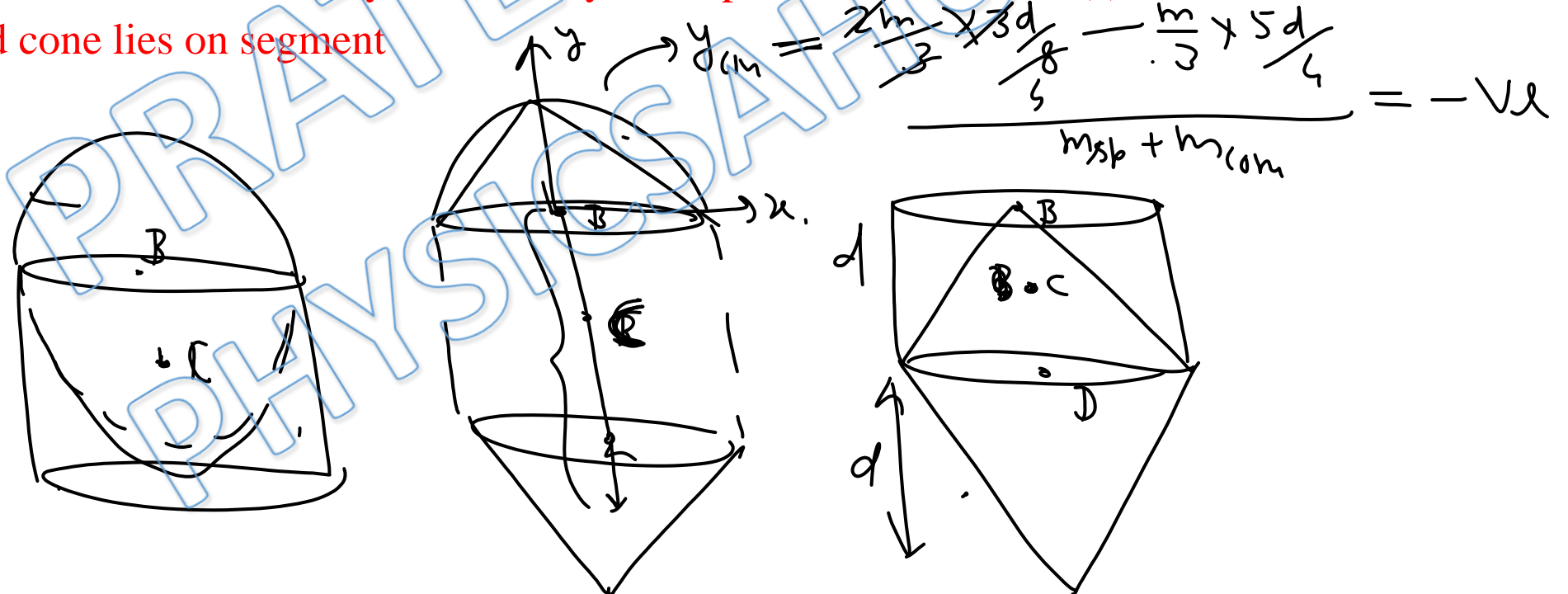

Q)14 An object comprises of a uniform ring of radius  $R$  and its uniform chord  $AB$  (not necessarily made of the same material) as shown. Which of the following cannot be the centre of mass of the object?

(a)  $(R/3, R/3)$

✓ (b)  $(R/\sqrt{2}, R/\sqrt{2})$

(c)  $(R/4, R/4)$

(d) None of the above

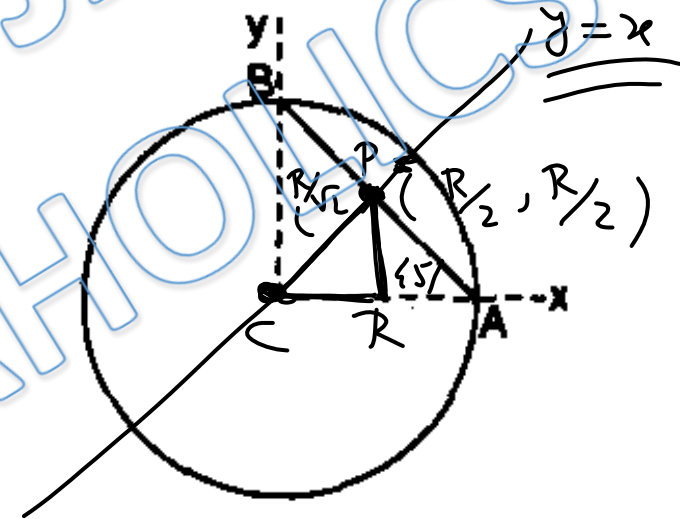

Q)15 Section AOB is cut from a uniform circular plate of radius R. find distance of centre of mass of AOB from O if  $\theta$  is very small angle?

(a) R

(b) R/2

(c) 2R/3

(d) R/3

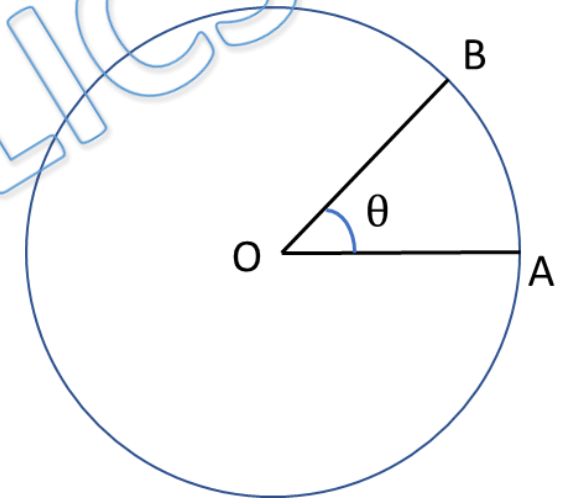
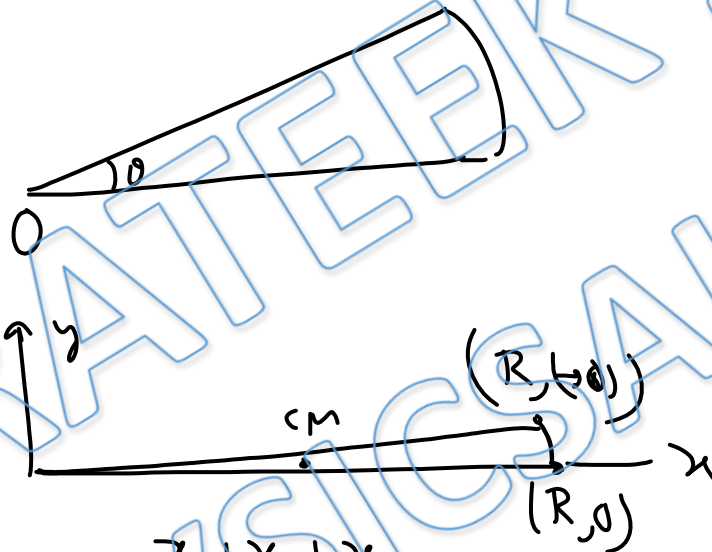

$$\begin{aligned}x_{cm} &= \frac{x_1 + x_2 + x_3}{3} \\ &= \frac{0 + R + R}{3} \\ &= \frac{2R}{3}\end{aligned}$$



Q)16 A uniform solid sphere of radius R is divided into four equal parts . Distance of centre of mass of one part from centre of complete sphere is

(a)  $3R/8$

~~(b)  $3\sqrt{2} R/8$~~

(c)  $3R/4$

(d)  $R/4$

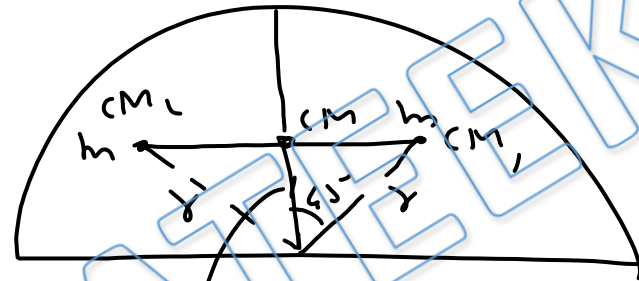

$$r \cos 45^\circ = \frac{3R}{8}$$

$$r = \frac{3\sqrt{2} R}{8}$$

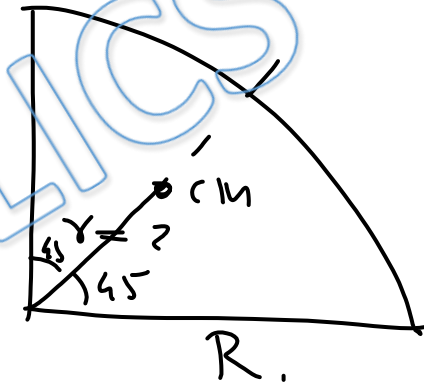

Q)17 Mark correct statements

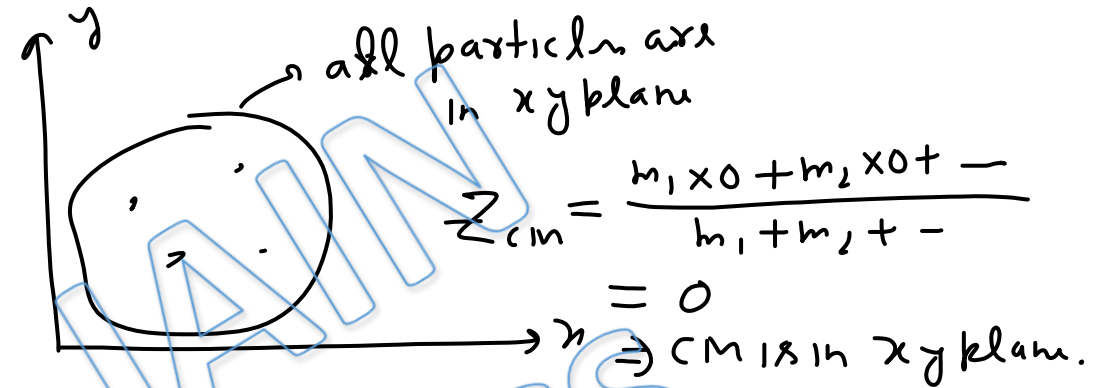

- (a) If all particles of a system are lying in a plane centre of mass of system must be in same plane.
- (b) If all particles of a system are lying in a spherical volume centre of mass of system must be in that spherical volume.
- (c) If all particles of a system are lying in a cubical volume centre of mass of system must be in that cubical volume.
- ~~(d) There must be some mass at position of centre of mass~~

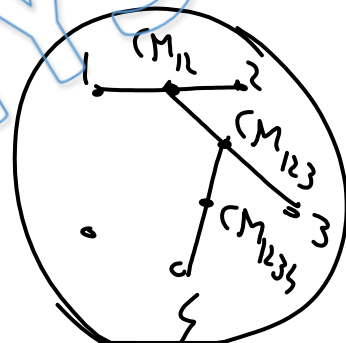

**For Video Solution of this DPP, Click on below link**

Video Solution  
on Website:-

<https://physicsaholics.com/home/courseDetails/76>

Video Solution  
on YouTube:-

<https://youtu.be/INfECcGDkjc>

Written Solution  
on Website:-

<https://physicsaholics.com/note/notesDetails/81>

 **SUBSCRIBE**



[@Physicsaholics](#)

[@Physicsaholics\\_prateek](#)

[@NEET\\_Physics](#)

[@IITJEE-Physics](#)

[physicsaholics.com](#)

[Unacademy](#)



**CLICK**

Chalo Niklo